

# JT 桌上型除振台安裝說明

## JT Desktop vibration isolation base

安裝前，請確認避震器之型號規格是否正確。

Before installation, make sure the model and the specification are correct.

### 安裝說明

### Installation guide

- 所需工具：氣壓源(最大使用內壓為 $4.5\text{kg/cm}^2 = 0.44\text{Mpa}$ )。

Required tools: Air pressure source (Maximum inner pressure is  $4.5\text{kg/cm}^2 = 0.44\text{Mpa}$ )

- 將除振台及附件自紙箱取出檢查附件是否齊全、除振台有無缺陷破損。(如圖1)

Take out the vibration isolation base and other accessories from the box to check if there is any damage (Fig 1).



型號 Type	JT0405A	JT0605A	JT0705A	JT0806A
長*寬 (mm) Length*Width	400*500	600*500	700*500	800*600
高 Height (mm)	58±3			
製品重量 Weight of the products	22 Kg	32 Kg	37 Kg	48 Kg
附屬品 Accessories	A Type : 1.PU空壓管(外徑Φ6mm*長3M) 2.空氣定壓過濾器 3.六角板手 A Type : 1.PU pressure pipe 6*3M 2.Constant pressure air filter 3.Hex Wrench			
最大荷重 Maximum loading	120&300 Kg			

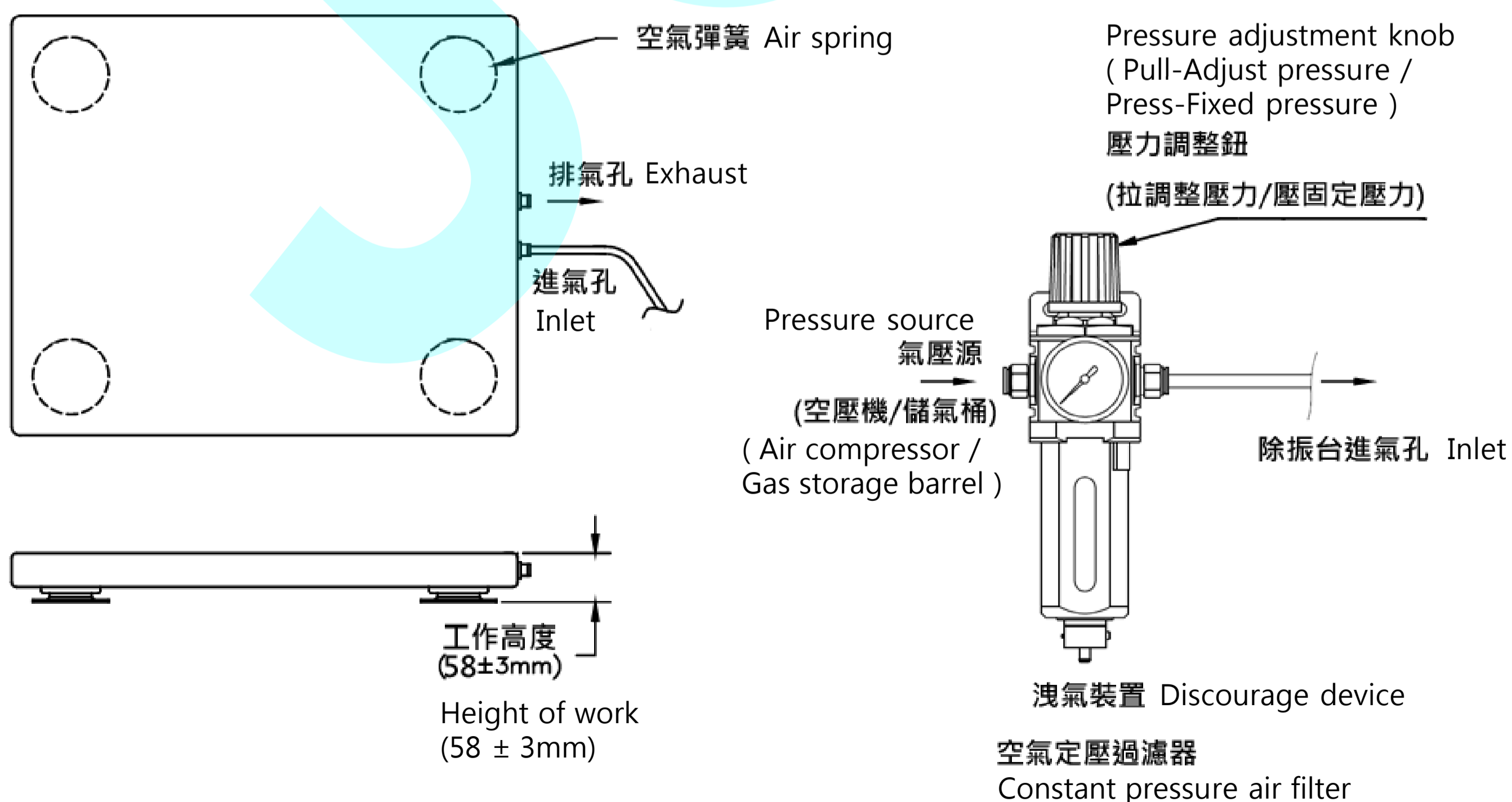

# JT 桌上型除振台安裝說明

## JT Desktop vibration isolation base

### 安裝說明

### Installation guide

- 將除振台放置在平台上，(此平台剛性須能承受除振台及受壓之重量)

Place the base on the panel (this panel can bear the weight from the base and the pressure) (Fig 2).

- 將PU管如圖，完成空壓管配線。(如圖3)

Install air pressure pipes according to the PU piping diagram (Fig 3).

- 將搭載物置於除振台中央使空氣彈簧荷重保持平均，依據搭載物重量依下表調整空氣定壓過濾器之壓力。(如圖4) ( $1\text{kg}/\text{cm}^2=0.098\text{Mpa}$ )

Place the loading at the central of the base to remain the balance of air spring. Adjust the pressure of constant pressure air filter according to the weight of the loading (Fig 4). ( $1\text{kg}/\text{cm}^2=0.098\text{Mpa}$ )

荷重 Loading weight	0~60 Kg	60~120 Kg
壓力 Pressure	0.2 Mpa	0.3 Mpa

- 壓力設定後，空氣源輸送空氣至除振台空氣彈簧；此時除振台會升高至正常使用高度(如圖5)。

After setting up the pressure, air will be delivered to the air spring inside the base through the air source. The base will be elevated to its regular application height (Fig 5).

- 插入六角扳手後，向順時針或逆時針可控制空氣彈簧的高度來調整除振台水平。(如圖6)

After insert the hex wrench, please do clockwise or anti-clockwise to control the leveling height of air spring in order to balance the leveling of the entire platform.(Fig 6).

- 如發現除振台某個空氣彈簧無法升高，可能原因為空氣壓力不足或高度調整有問題，請檢查此2項目。

If any air spring is not able to raise, it may be caused by insufficient air pressure or height adjustment . Please check the following 2 items when there is a problem.

※ 保養點檢項目：每月觀察定壓過濾器內壓是否正常&積水需排除、保持除振台安裝狀態正常。

Maintenance checking points: check the inner pressure of the constant pressure filter, remove standing water, and maintain the installation status of the base.

※移動設備前請先放氣；以免造成氣墊損壞。

Deflate the air through the valve to avoid the damage before moving the equipment.



# JT 桌上型除振台安裝說明

## JT Desktop vibration isolation base



圖1)將除振台及附件自紙箱取出檢查附件是否齊全除振台有無缺陷破損

Fig 1) Take out the vibration isolation base and other accessories from the box to check if there is any damage.

圖2將除振台放置在平台上。

Fig 2) Place the base on the panel.

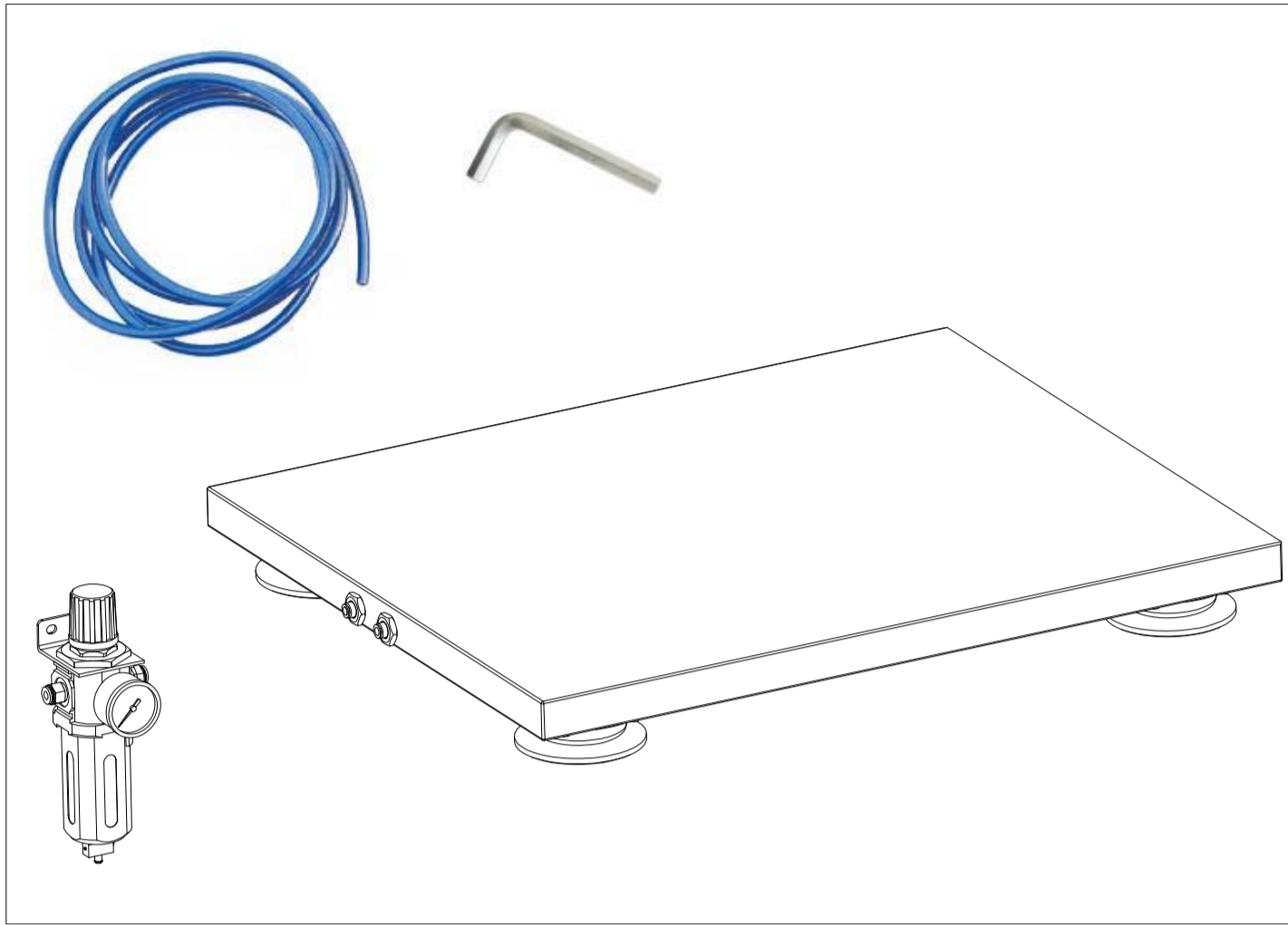

圖3)將PU管如圖，完成空壓管配線

Fig 3) Install air pressure pipes according to the PU piping diagram.

JT 桌上型除振台安裝說明  
JT Desktop vibration isolation base

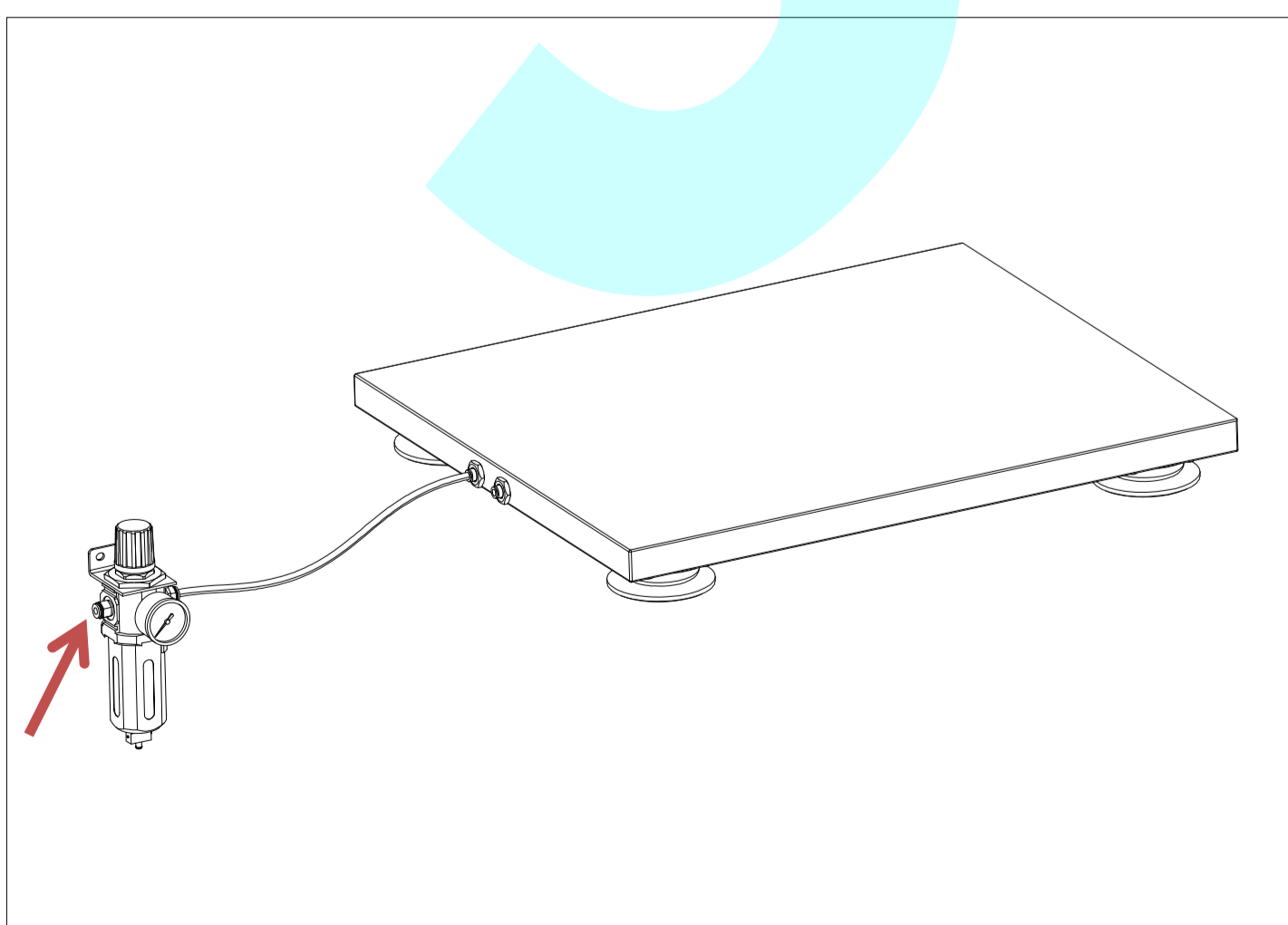
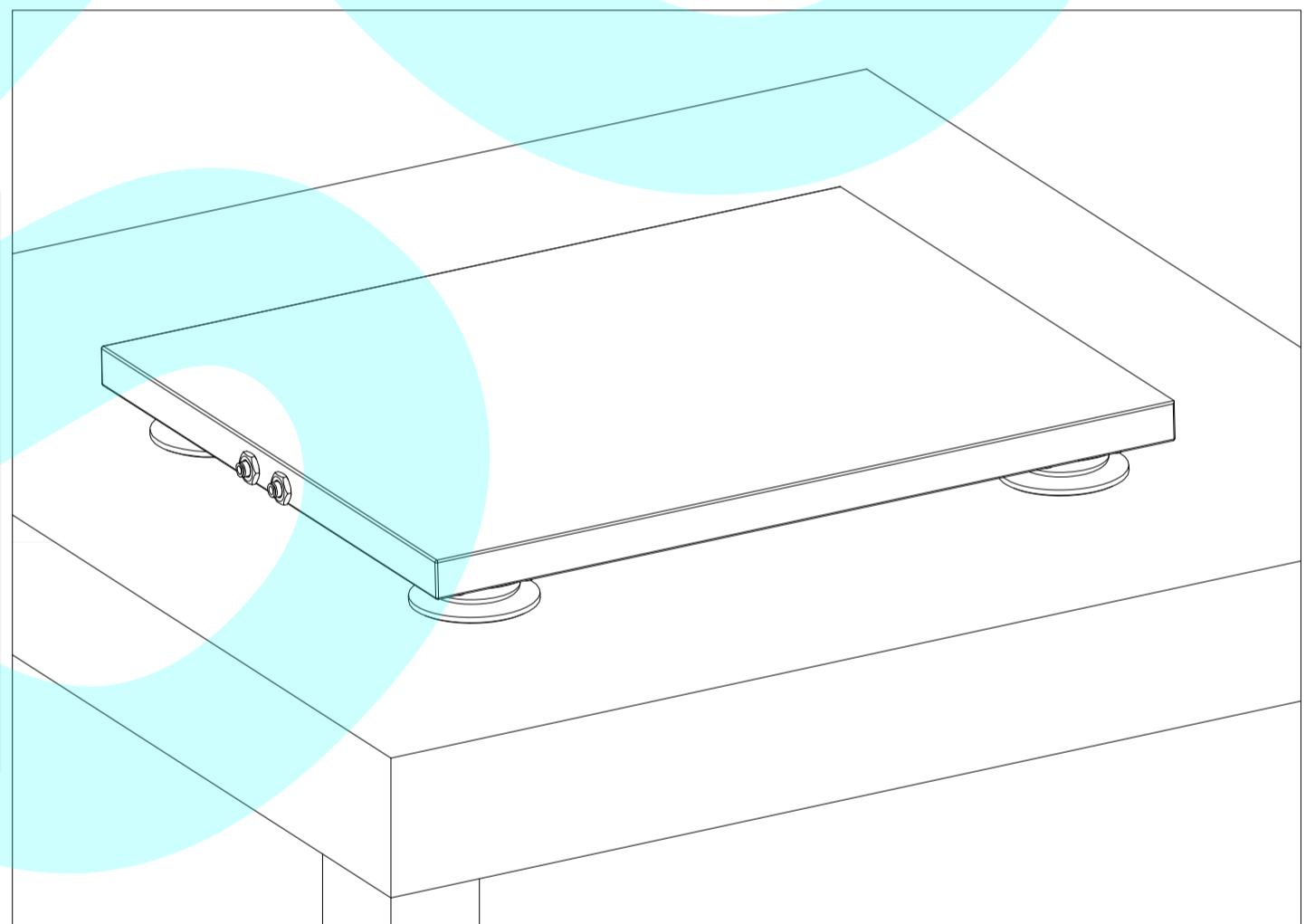

圖4) 依據搭載物重量依下表調整空氣定壓過濾器之壓力。

Fig 4) Adjust the pressure of constant pressure air filter according to the weight of the loading.

圖5) 壓力設定後，空氣源輸送空氣至除振台空氣彈簧；此時除振台會升高至正常使用高度。

Fig 5) After setting up the pressure, air will be delivered to the air spring inside the base through the air source. The base will be elevated to its regular application height.

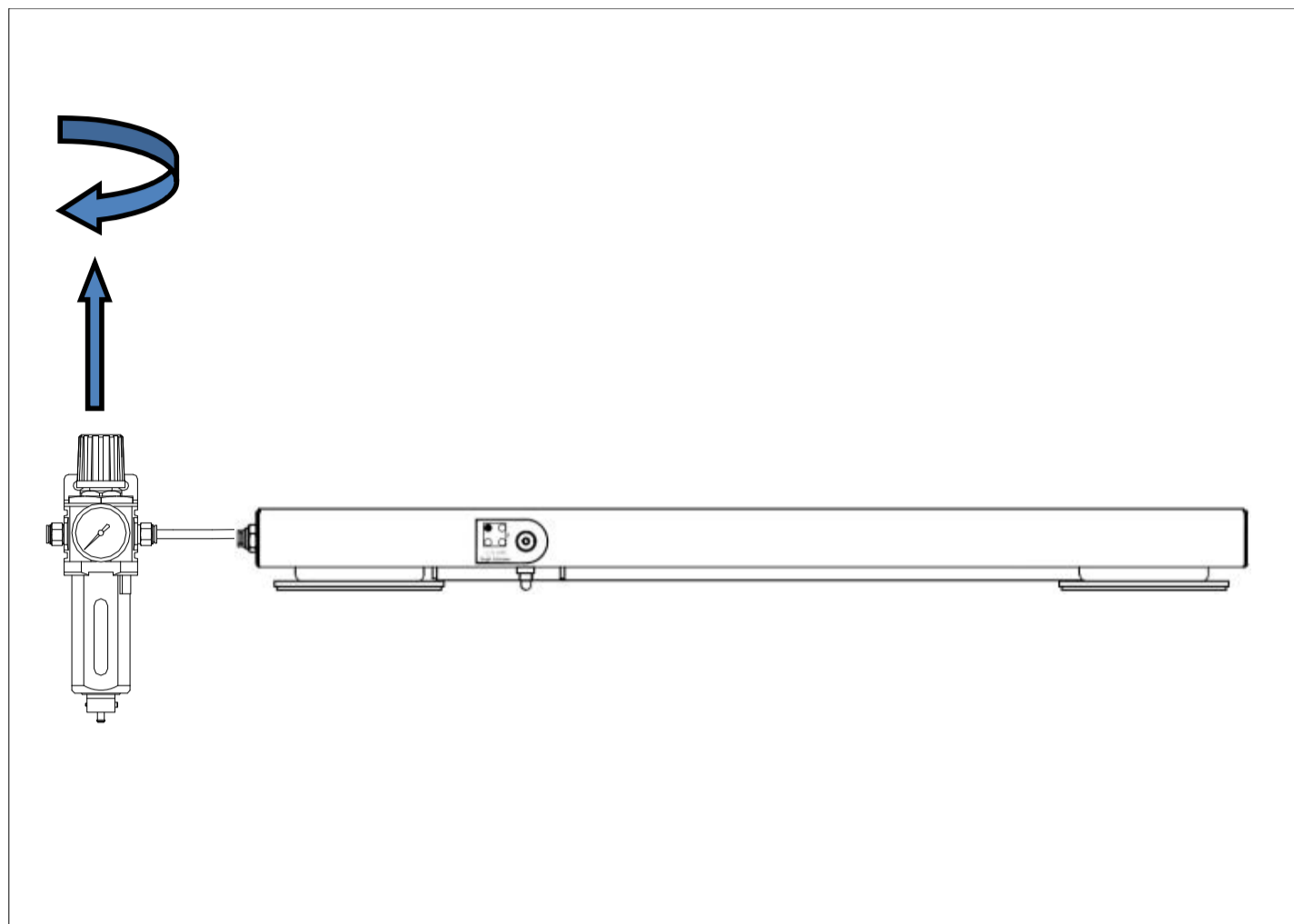
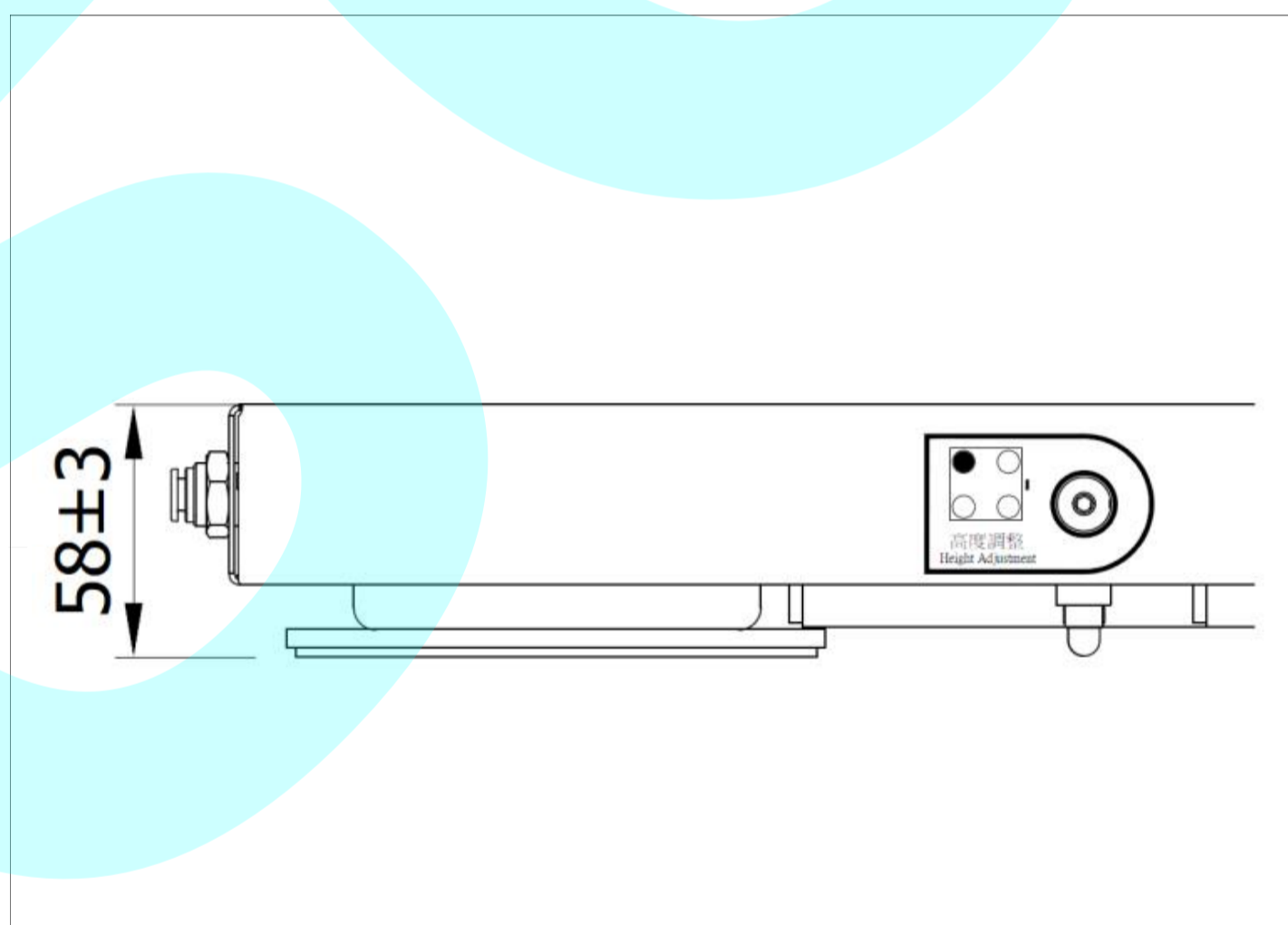

進排氣口方向  
intake and exhaust

插入六角板手  
Insert hex wrench

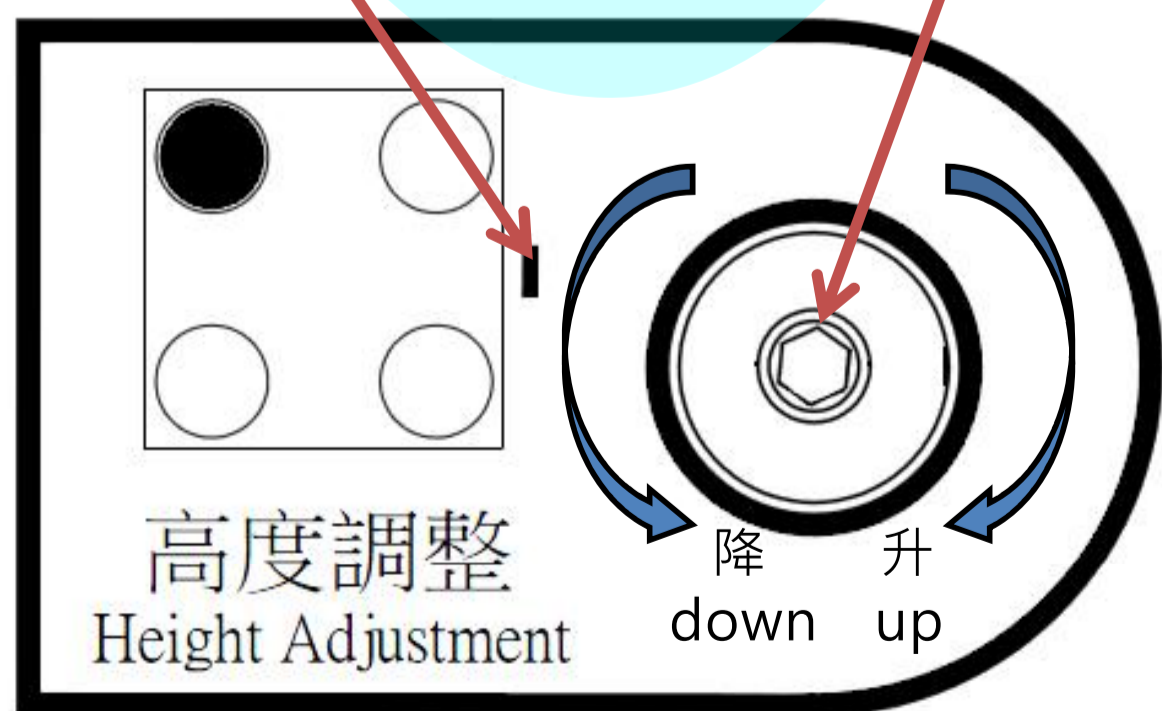

圖6) 插入六角板手後，向順時針或逆時針可控制空氣彈簧的高度來調整除振台水平。

Fig 6) After insert the hex wrench, please do clockwise or anti-clockwise to control the leveling height of air spring in order to balance the leveling of the entire platform.