

JH 型懸吊式避震器安裝說明

JH Hanger installation guide

安裝前，請確認避震器之型號規格是否正確。

Before installation, make sure the model and the specification are correct.

安裝說明

Installation guide

- 所需工具：公制口徑17mm (M10)、19mm (M12)、24mm (M16) 開口扳手。

Required tools: 17mm(M10), 19mm(M12), and 24mm(M16) open wrenches.

- 先於安裝位置處依據施工規範預埋符合荷重要求之基礎螺栓。(如圖1)

Embed required foundation bolts according to the loading on the installation location (Fig 1).

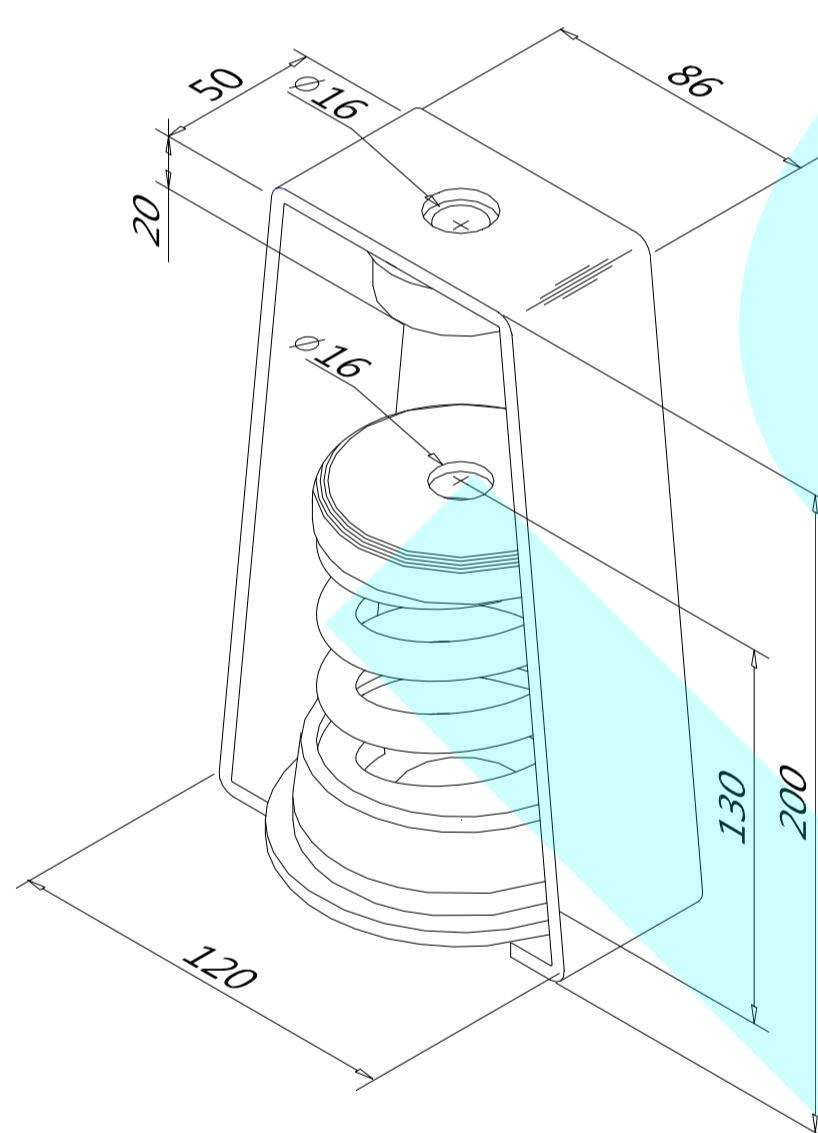

JH-MR

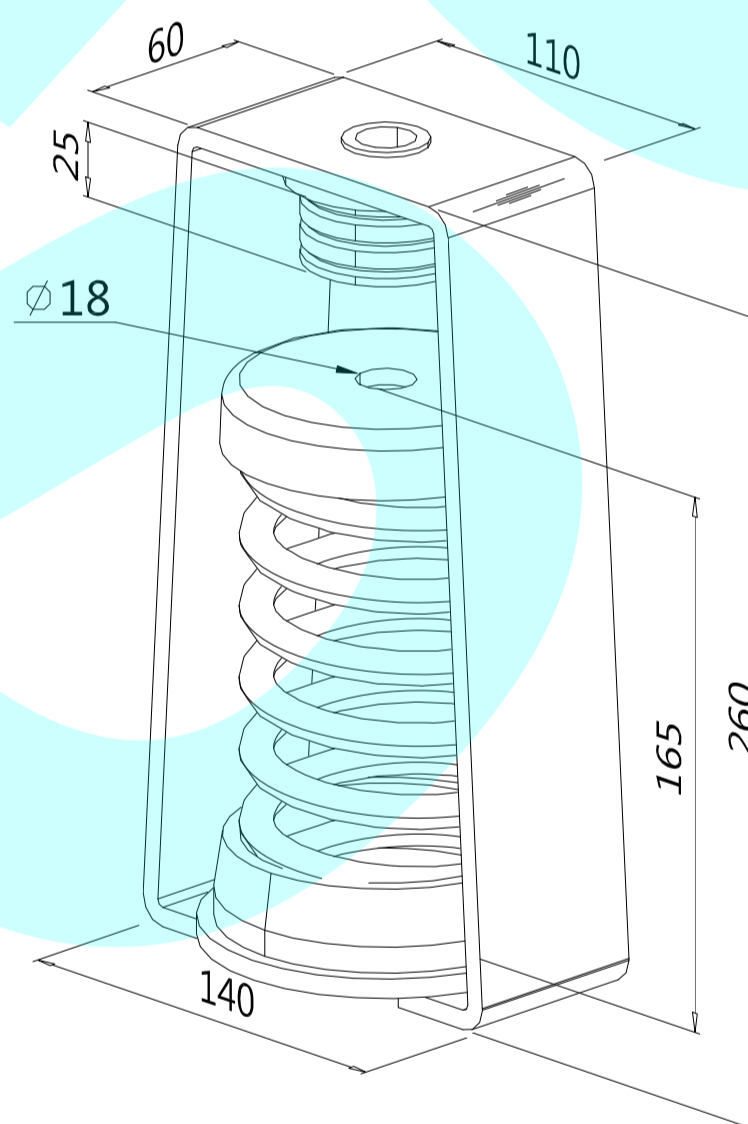

JH-D

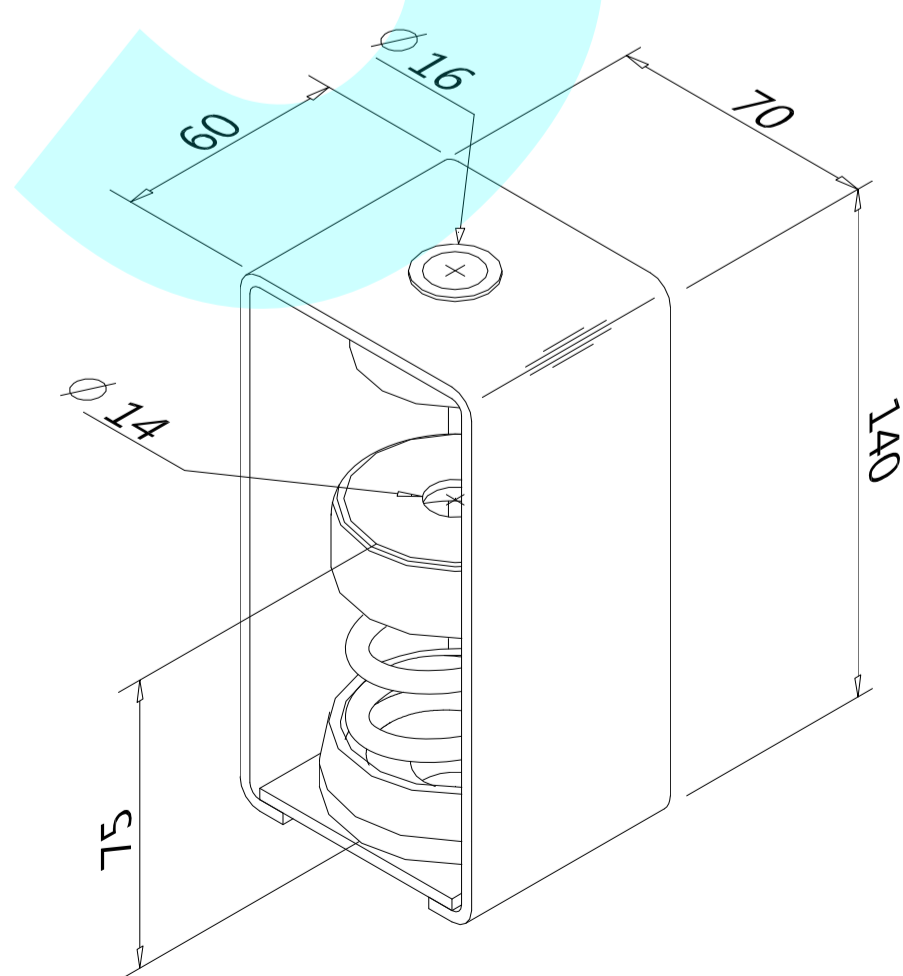

JH-SR

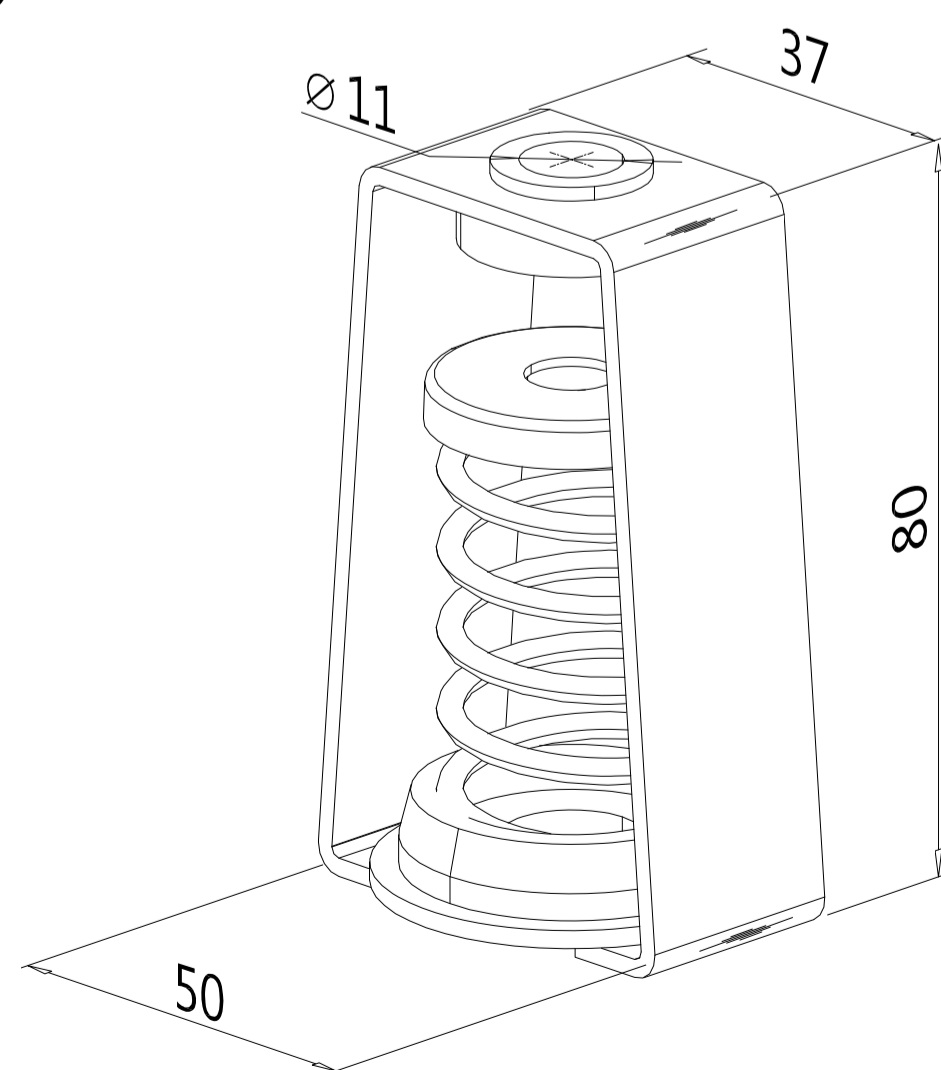

JH-SS

JH 型懸吊式避震器安裝說明

JH Hanger installation guide

安裝說明

Installation guide

- 利用華司及螺帽將避震器固定於安裝位置的預埋螺栓。(如圖2)

Elevate the equipment to the same height as the wooden panel with claw jack gradually (Fig 2).

- 將避震器與設備連結的牙條裝上。(如圖3)

Install the hread rod connecting the hanger and the equipment (Fig 3).

- 使用上下2顆螺帽安裝與設備連接的固定處，以方便調整；此時上部螺帽不須鎖固。(如圖4)

Apply upper and lower nuts to fasten the installation on the equipment so it is easy to adjust. Do not lock the upper nuts (Fig 4).

- 將設備安裝或配管安裝完成。

Complete the equipment and piping engineering installation.

- 使用開口扳手調整下部螺帽來調整設備水平及彈簧壓縮量。(如圖5)

Apply the open wrench to adjust lower nuts for the balance of the equipment and the press amount for the spring (Fig 5).

- 調整完成後將上下兩顆螺帽相對鎖固之，即可完成避震器安裝調整。(如圖6)

Lock the upper and lower nuts after adjusting (Fig 6).

- 安裝後請檢查彈簧之下壓量，如彈簧壓實表示荷重不足無避震效果。應予更換較大荷重之規格，並請洽本公司業務人員。

After the adjustment, check the press amount of the spring. If it appears with insufficient loading, please replace with bigger loading by contacting our staff.

- 安裝時，請注意安全。

Be cautious during the installation.

※ 保養點檢項目：每月觀察鎖固螺栓保持鎖固無脫離、保持避震器安裝狀態&彈簧下壓撓度正常。

Maintenance checking points: remain fixed bolt and foundation bolt locked, installation of the hanger, and the deflection of the spring monthly.



JH 型懸吊式避震器圖解說明

JH Hanger illustration



圖1)在安裝位置依據施工規範預埋符合荷重要求之基礎螺栓。

Fig 1) Embed required foundation bolts according to the loading on the installation location.

圖2)使用華司及螺帽將避震器與基礎螺栓固定於安裝位置上。

Fig 2) Fasten the hanger on the installation location with washer and nuts.

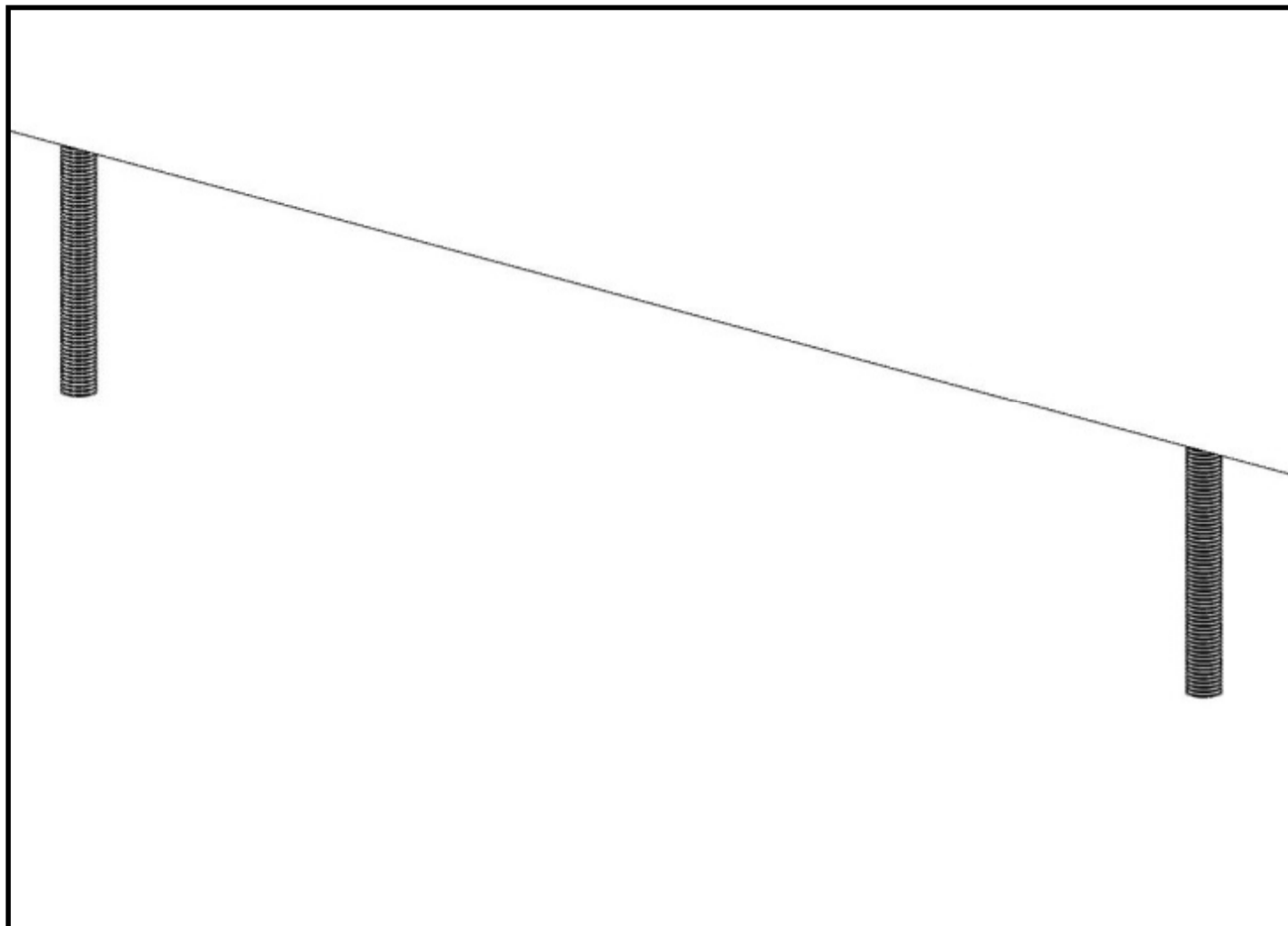

圖3)使用華司及螺帽固定與設備連結的牙條。

Fig 3) Install the hread rod connecting the hanger and the equipment

JH 型懸吊式避震器圖解說明 JH Hanger illustration

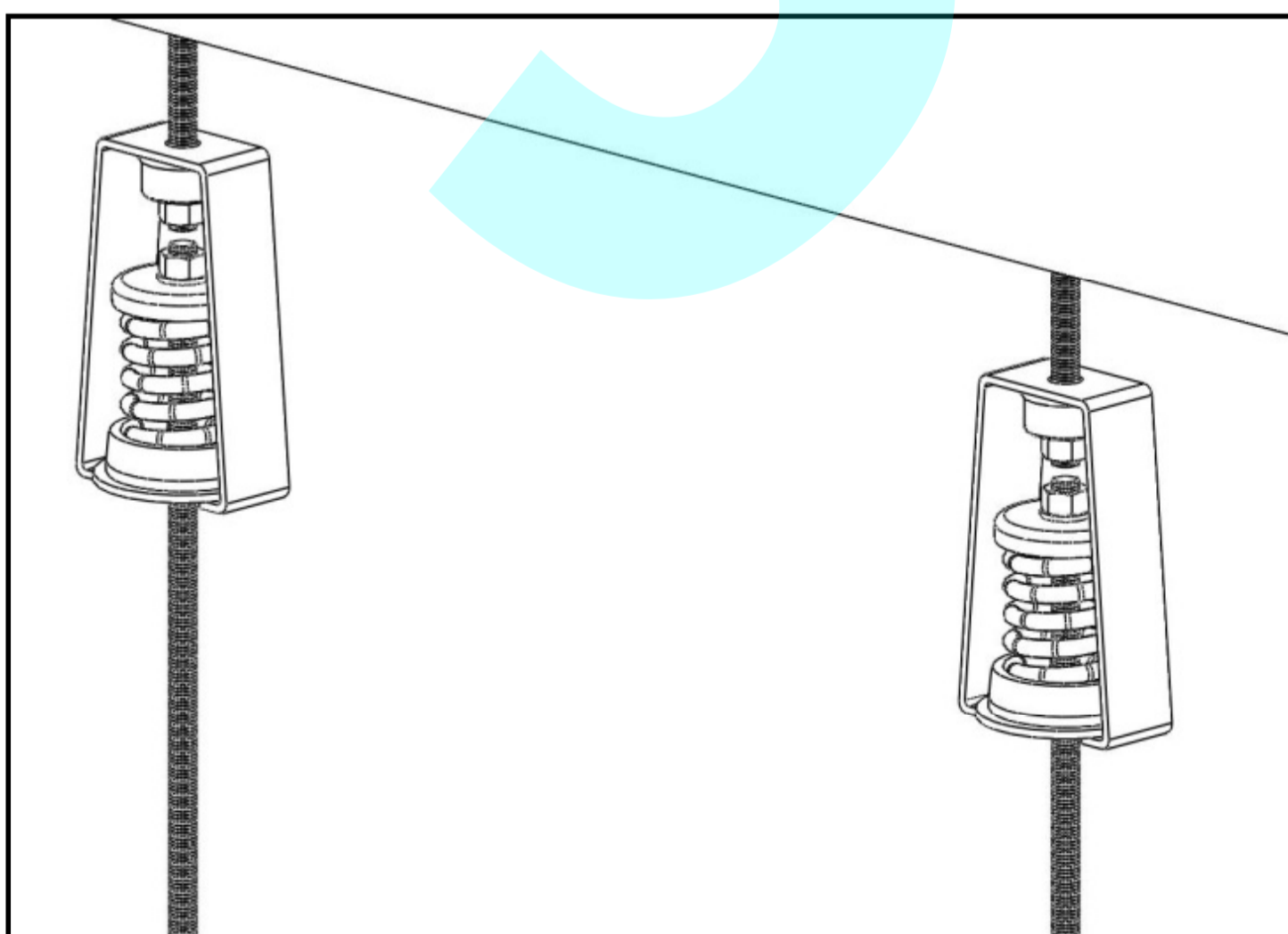
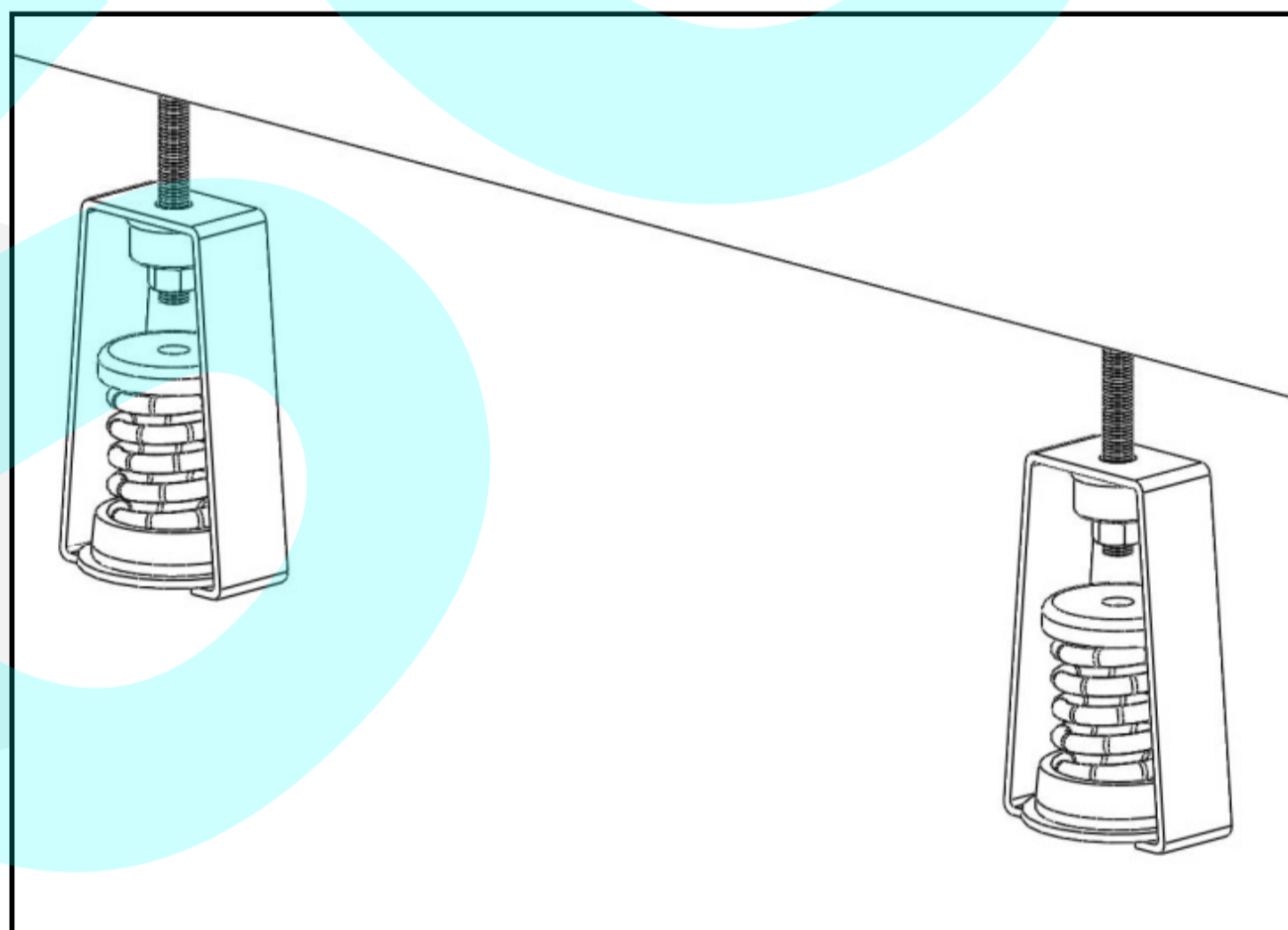

圖4)利用上下兩顆螺帽將設備與避震器作安裝，上部螺帽暫時不需鎖緊。

Fig 4) Apply upper and lower nuts to install the equipment and the hanger. Do not lock the upper nuts.

圖5)使用開口扳手調整下部螺帽來調整設備水平與彈簧壓縮量。

Fig 5) Apply the open wrench to adjust lower nuts for the balance of the equipment and the press amount for the spring.

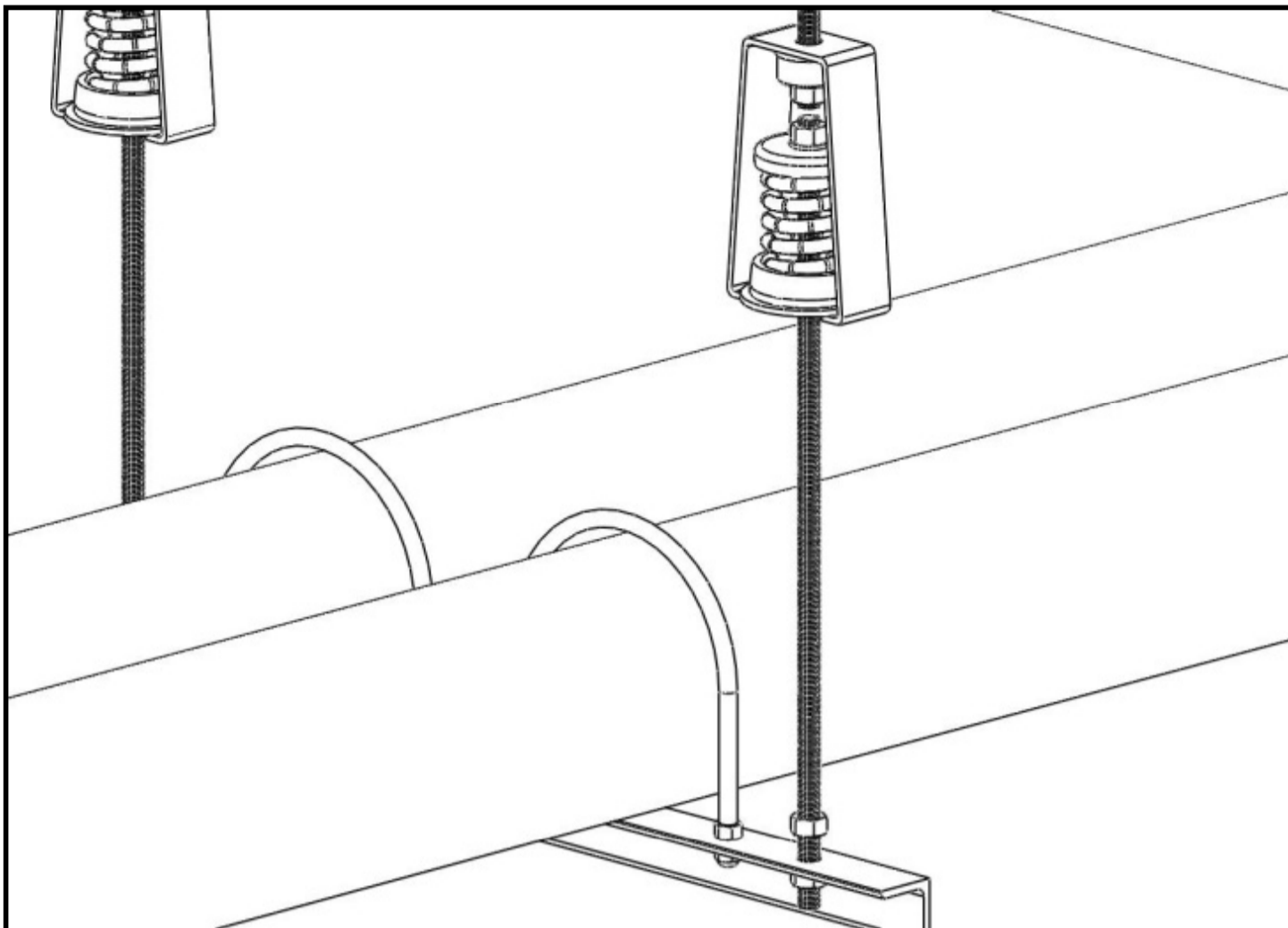
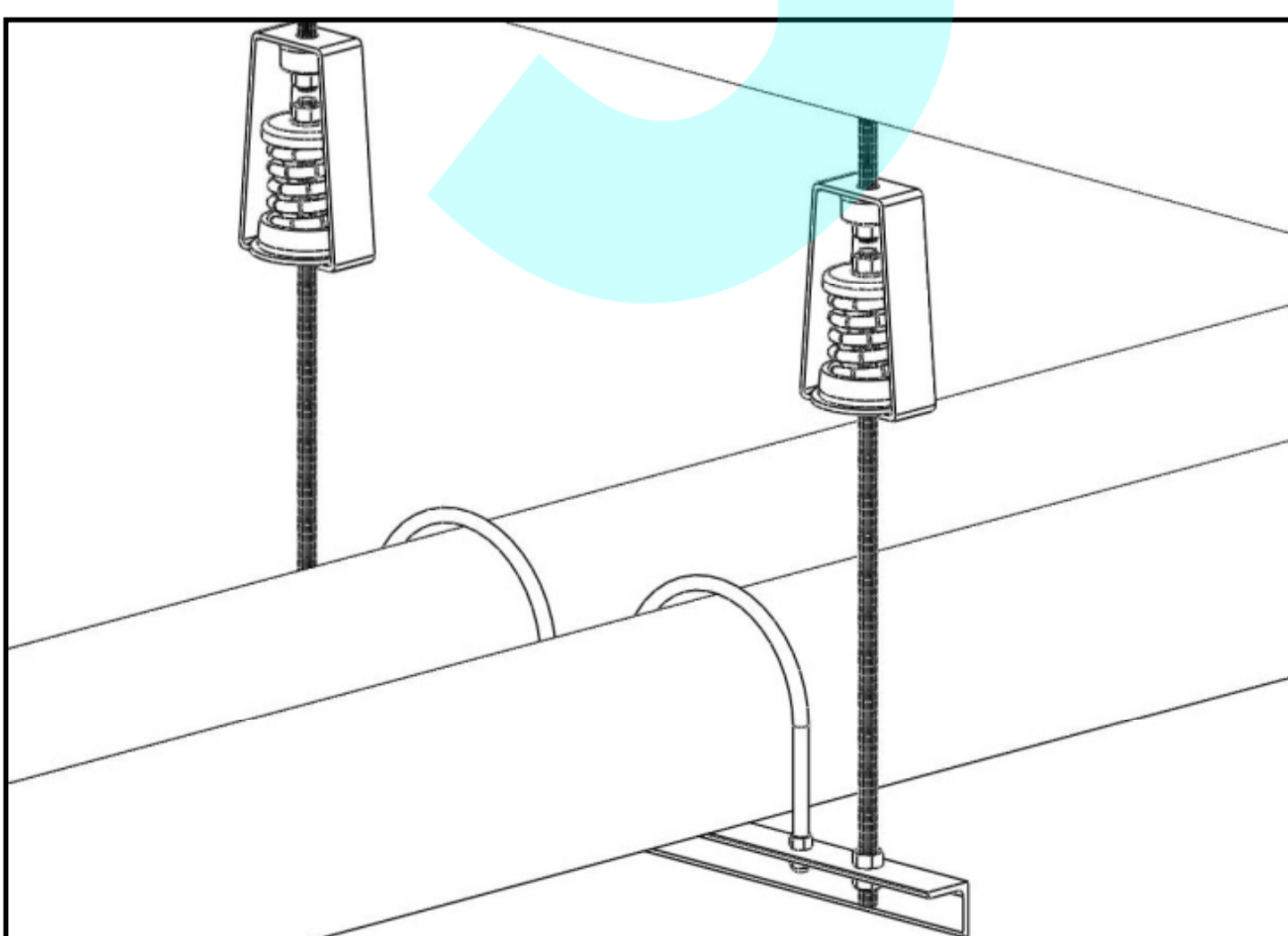
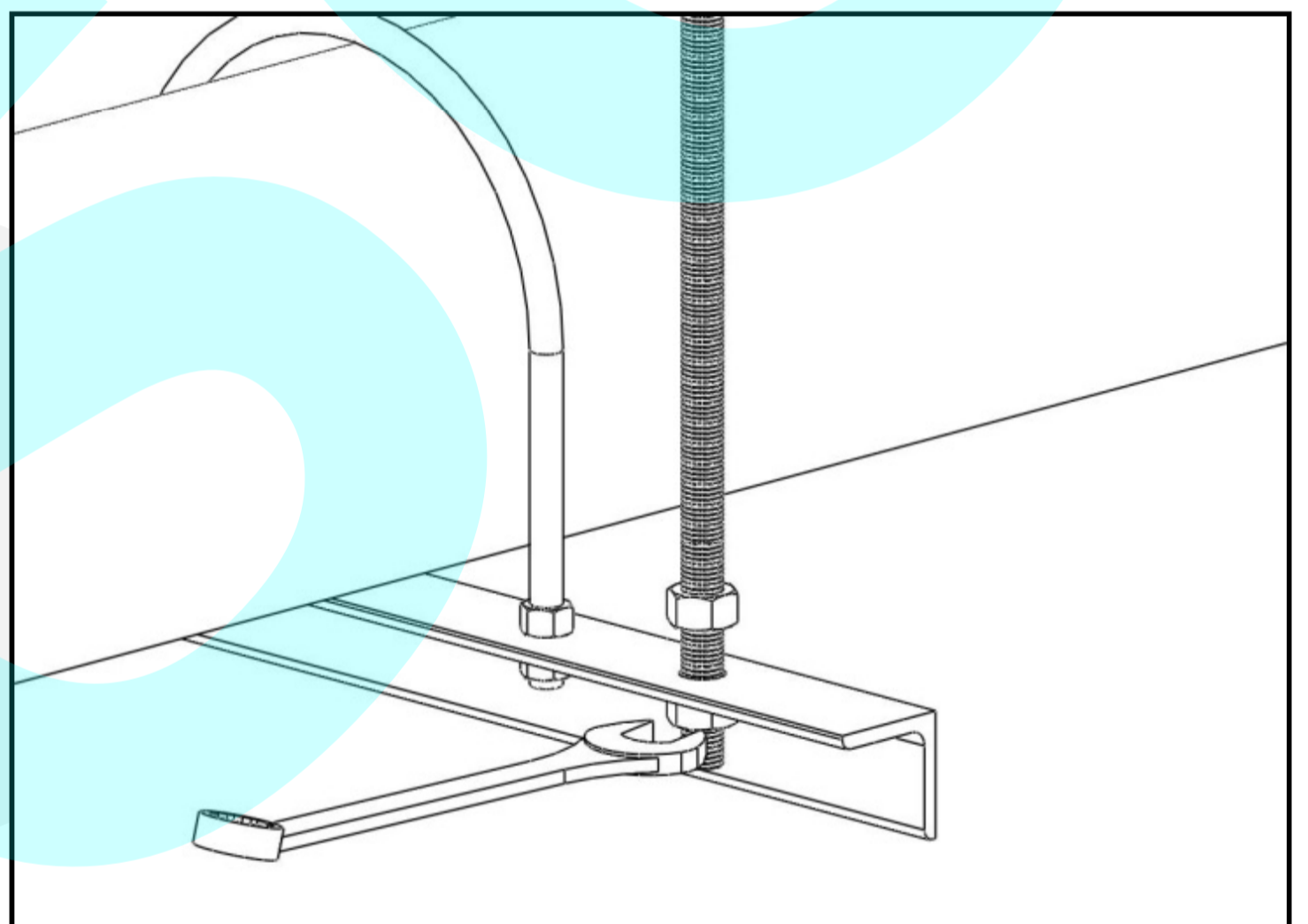

圖6)調整完畢後將上下兩顆螺帽相對鎖固，即可完成避震器安裝調整。

Fig 6) Lock the upper and lower nuts after adjusting.