

JB 型彈簧式避震器安裝說明

JB spring isolator installation guide

安裝前，請確認避震器之型號規格是否正確。

Before installation, make sure the model and the specification are correct.

安裝說明

Installation guide

- 所需工具：公制口徑17mm (M10)、19mm (M12)開口扳手、爪式千斤頂。

Required tools: 17mm (M10) and 19mm (M12) open wrenches and claw jack.

- 可先行放置與避震器高度相同的臨時木台於設備安裝處，再安裝設備。(如圖1)

Place the wooden panel with the same height as the isolator at the installation before installing (Fig 1).

- 先將固定螺栓的上部螺帽組取下，再放鬆下部之螺帽組使全牙螺栓下降，以方便將避震器置入安裝位置。(如圖2)

Remove the upper nuts from the fixed bolt. Loosen the lower nuts to descend the full-thread bolt to install the isolator (Fig 2).

- 依據基礎螺栓固定孔的位置，於安裝位置預埋基礎螺栓。

Embed foundation bolt according to the location of bolt-loaded holes.

- 將避震器放置於與設備的正確安裝位置。(如圖3)

Place the isolator on the correct installation location (Fig 3).



型號 Type	尺寸 Dimension (mm)					
	L	W	A	B	H	φCS
JB-M	210	86	185	149	185	M12
JB-N	210	86	185	149	185	M12
JB-S	150	65	130	104	130	M10
JB-SN	150	65	130	104	120	M10

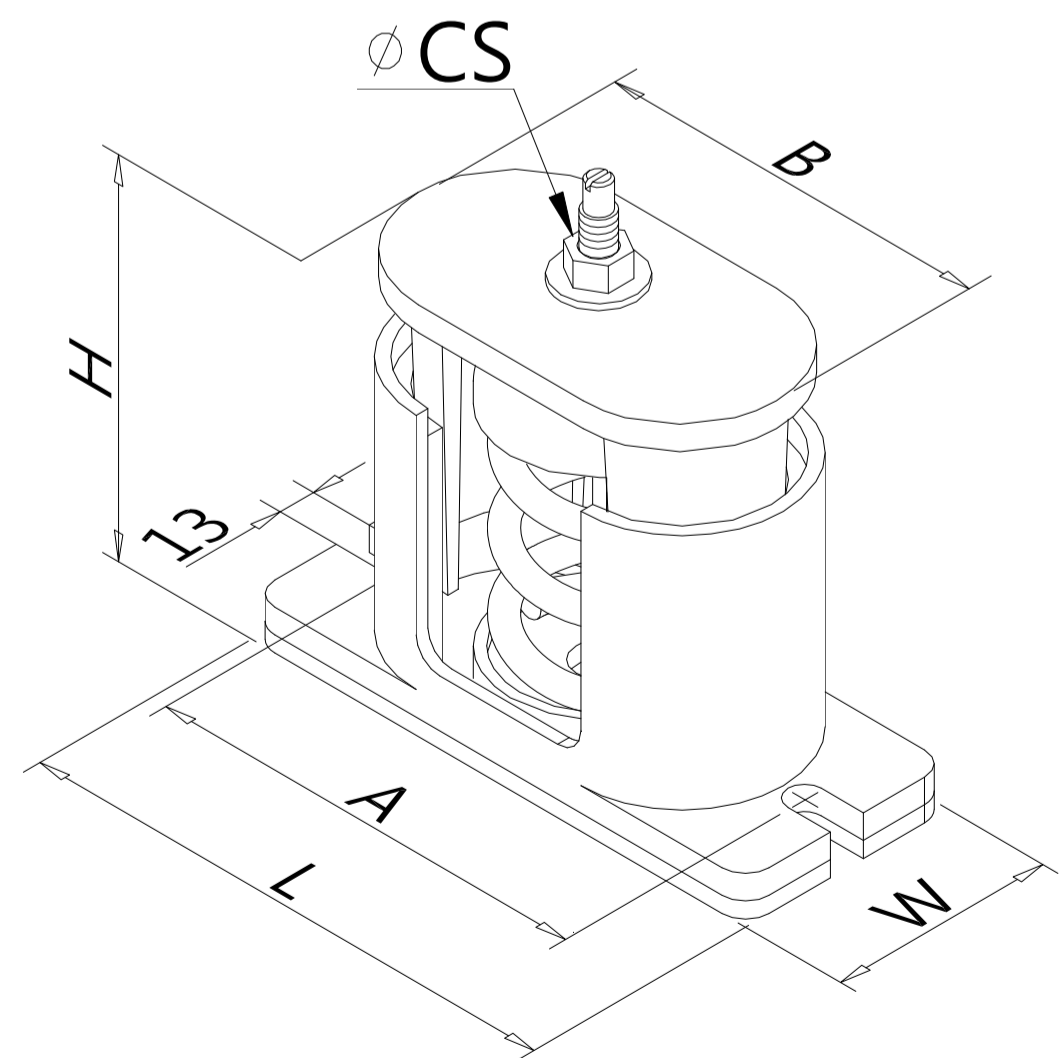

*JB-S 350&550 TYPE · H=142

JB 型彈簧式避震器安裝說明 JB spring isolator installation guide

- 調整下部螺帽組使全牙螺栓上升至與設備安裝處，並將上部螺帽組與全牙螺栓略為鎖緊。(如圖4))

Adjust lower nuts to raise the full-thread bolt for the installation and slightly lock the upper nuts and full-thread bolt (Fig 4).

- 使用開手扳手以順時針方向調整螺帽使彈簧受力下壓，調整至臨時木台可取出時即可停止調整。(如圖5)

Apply open wrench in the clockwise direction to press down the spring. Adjustment can be stopped and wooden panel can be removed once you can take out the pressure pad (Fig 5).

- 將固定螺栓確實完全鎖緊，即完成避震器之安裝調整。(如圖6)

After the adjustment, lock the isolator with fixed bolt (Fig 6).

- 安裝後請檢查彈簧之下壓量，如彈簧壓實表示荷重不足無避振效果。應予更換較大荷重之規格，並請洽本公司業務人員。

After the adjustment, check the press amount of the spring. If it appears with insufficient loading, please replace with bigger loading by contacting our staff.

- 安裝時，請注意安全。

Be cautious during the installation.

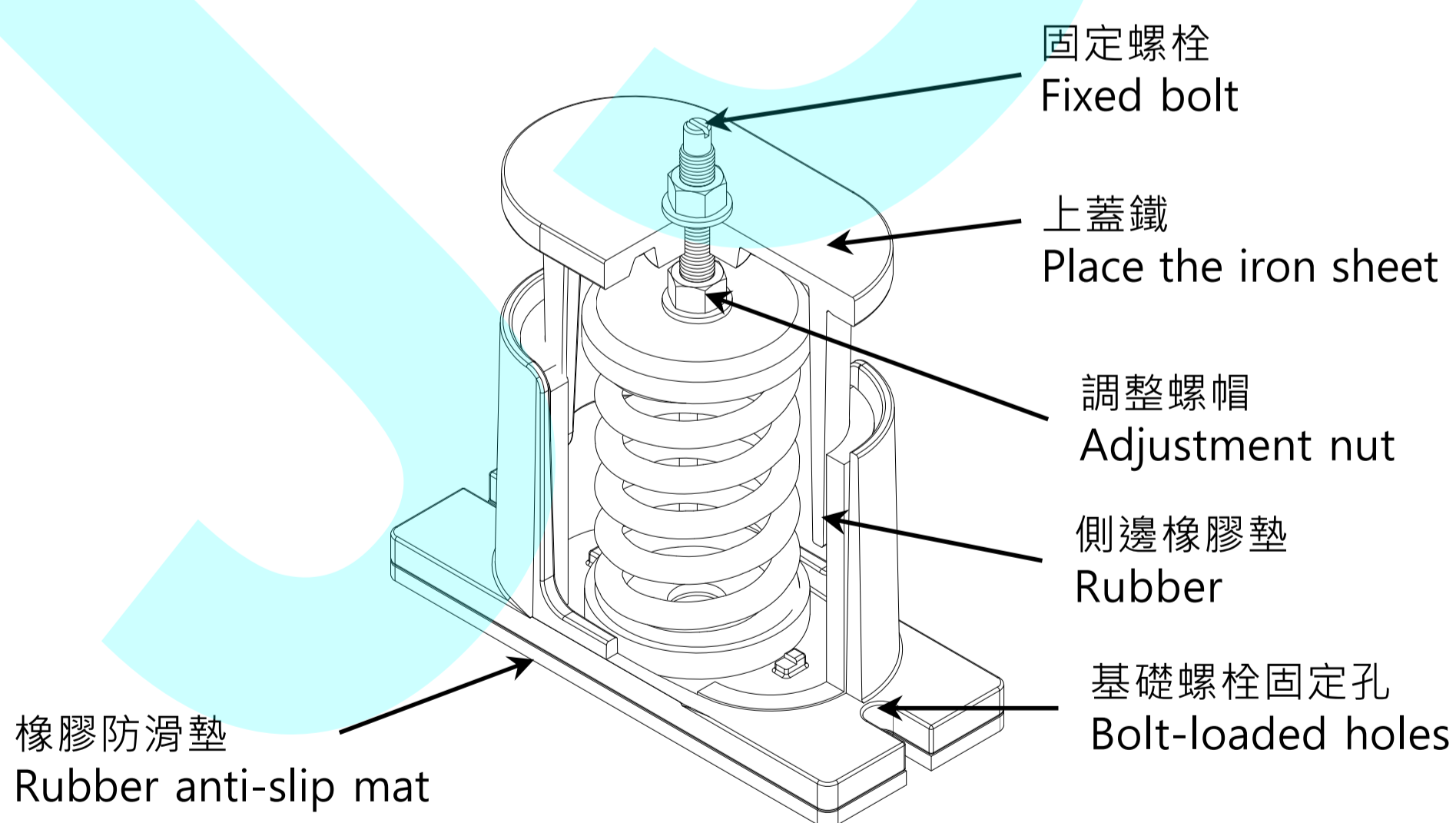

※保養點檢項目：每月觀察CS固定螺栓保持鎖固、保持避震器安裝狀態&彈簧下壓撓度正常。

Maintenance checking points: remain M12 fixed bolt locked, balance of the base, installation of the isolator, and the deflection of the spring.

JB 型彈簧式避震器圖解說明 JB spring isolator illustration



圖1)安裝設備時可先放置與避震器相同高度之臨時木台。

Fig 1) Place the wooden panel with the same height as the isolator at the installation before installing.

圖2)固定螺栓的上部螺帽組先行取下，再放鬆下部螺帽組使螺栓下降，以利安裝。

Fig 2) Remove the upper nuts from the fixed bolt. Loosen the lower nuts to descend the bolt for the installation.

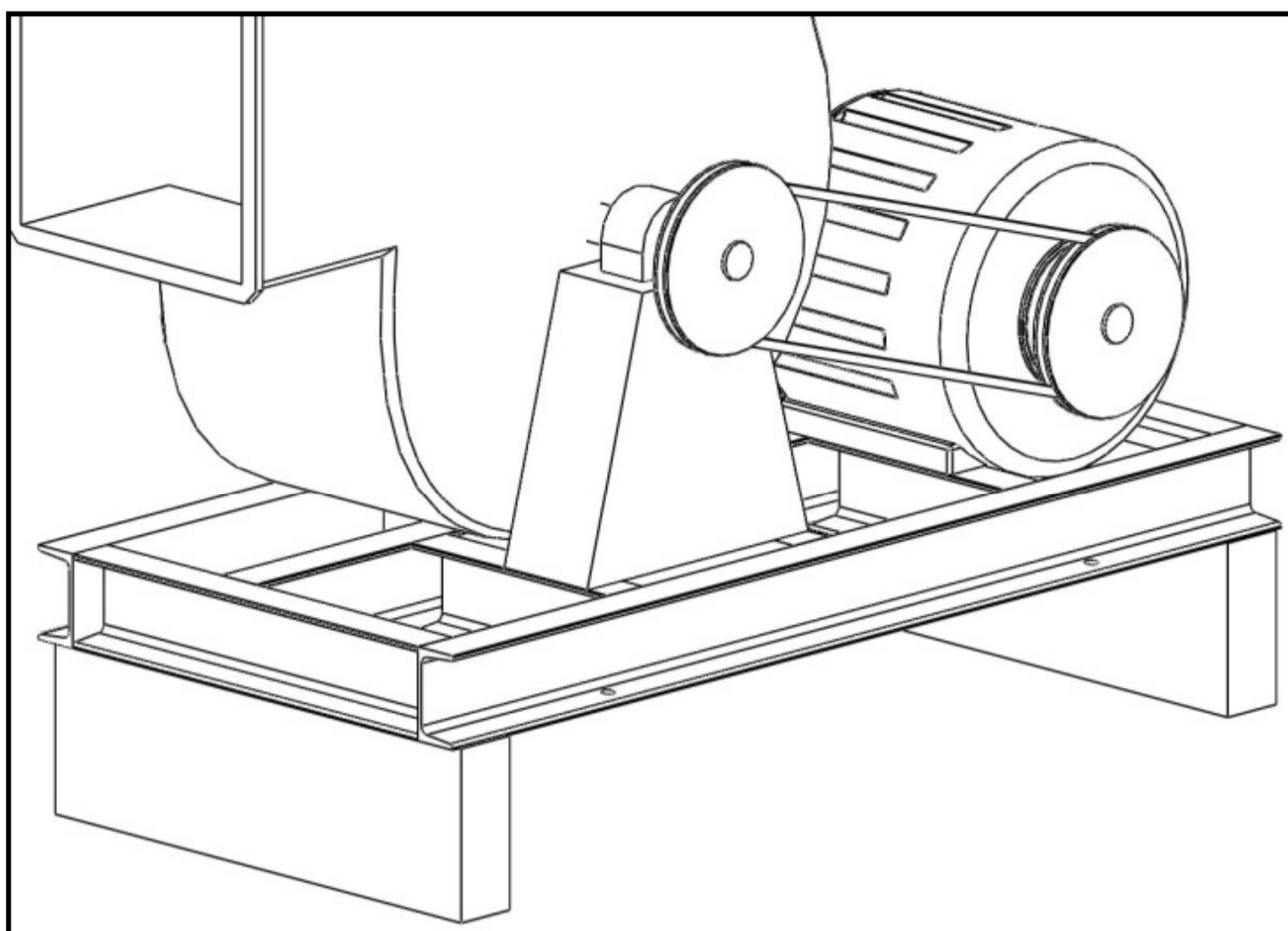

圖3)將避震器置入安裝機器之位置。

Fig 3) Place the isolator on the correct installation location.

JB 型彈簧式避震器圖解說明 JB spring isolator illustration

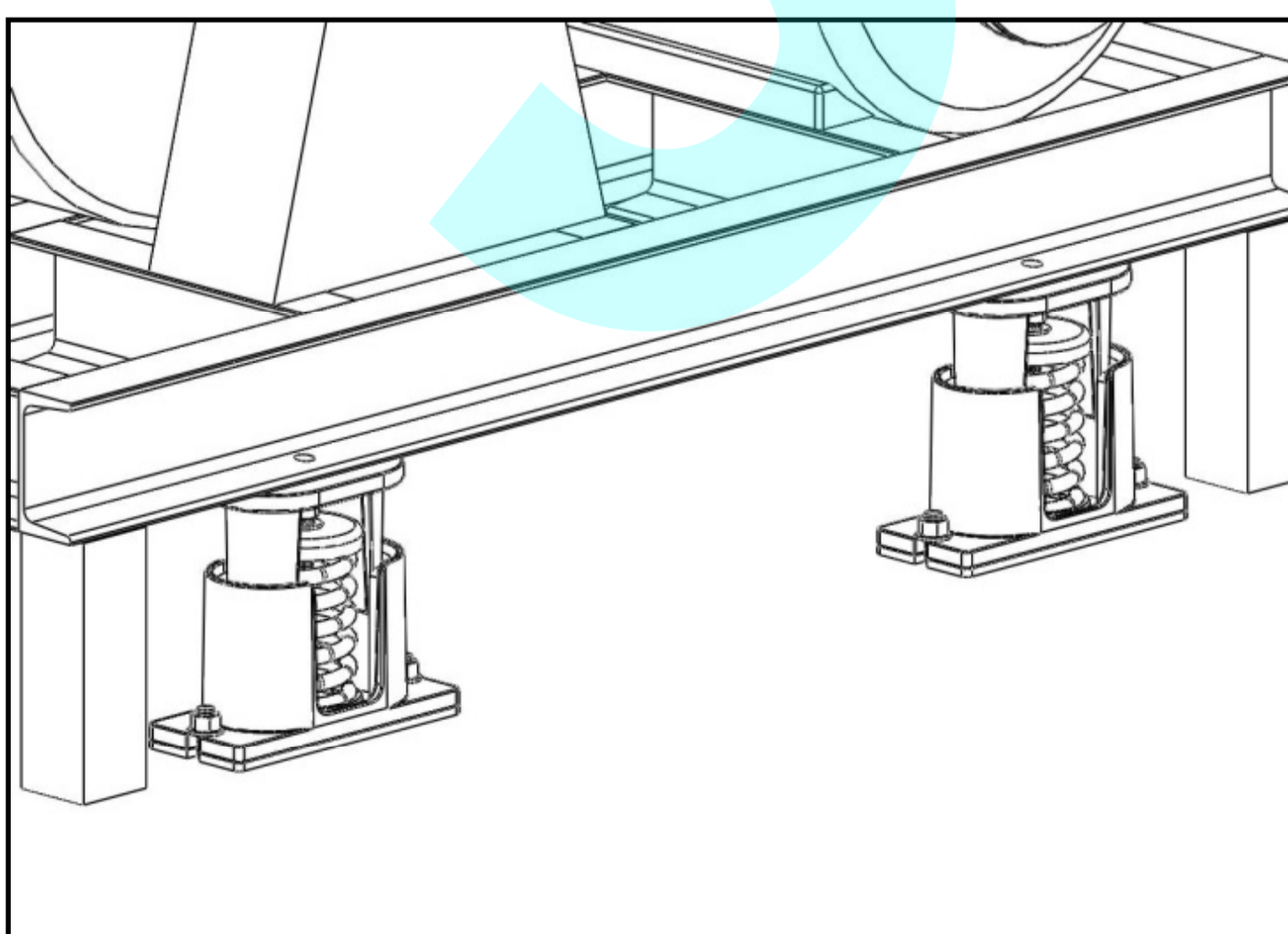
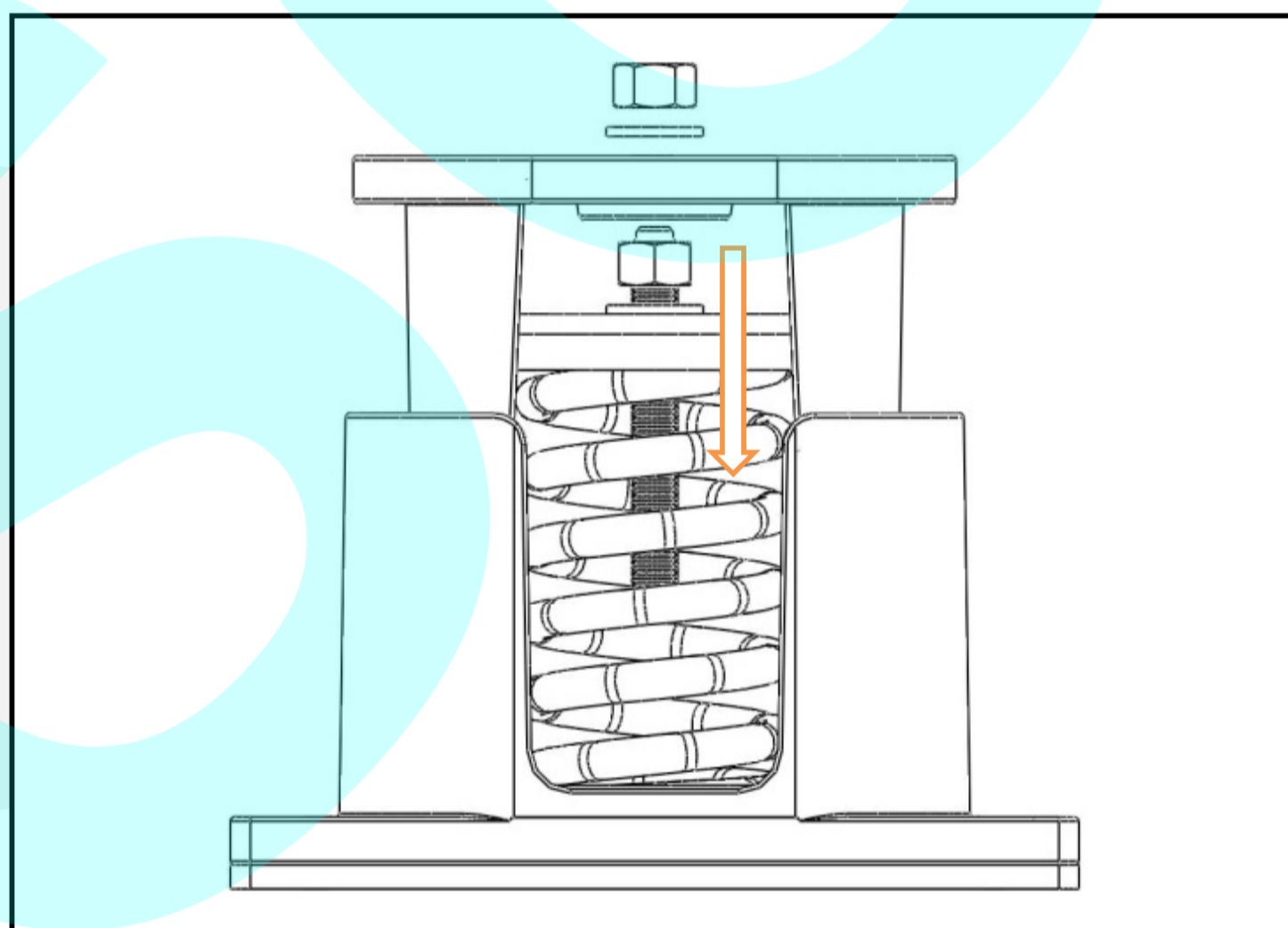

圖4)調整下部螺帽組使螺栓上升至能與設備連結，再將固定螺帽略為鎖緊。

Fig 4) Adjust lower nuts to raise the bolt to connect with the equipment and slightly lock the fixed nuts.

圖5)用開口扳手以順時針方向調整螺帽，調整至臨時木台可取出時即可停止調整。

Fig 5) Apply open wrench in the clockwise direction to adjust the nuts. Adjustment can be stopped once wooden panel is removed.

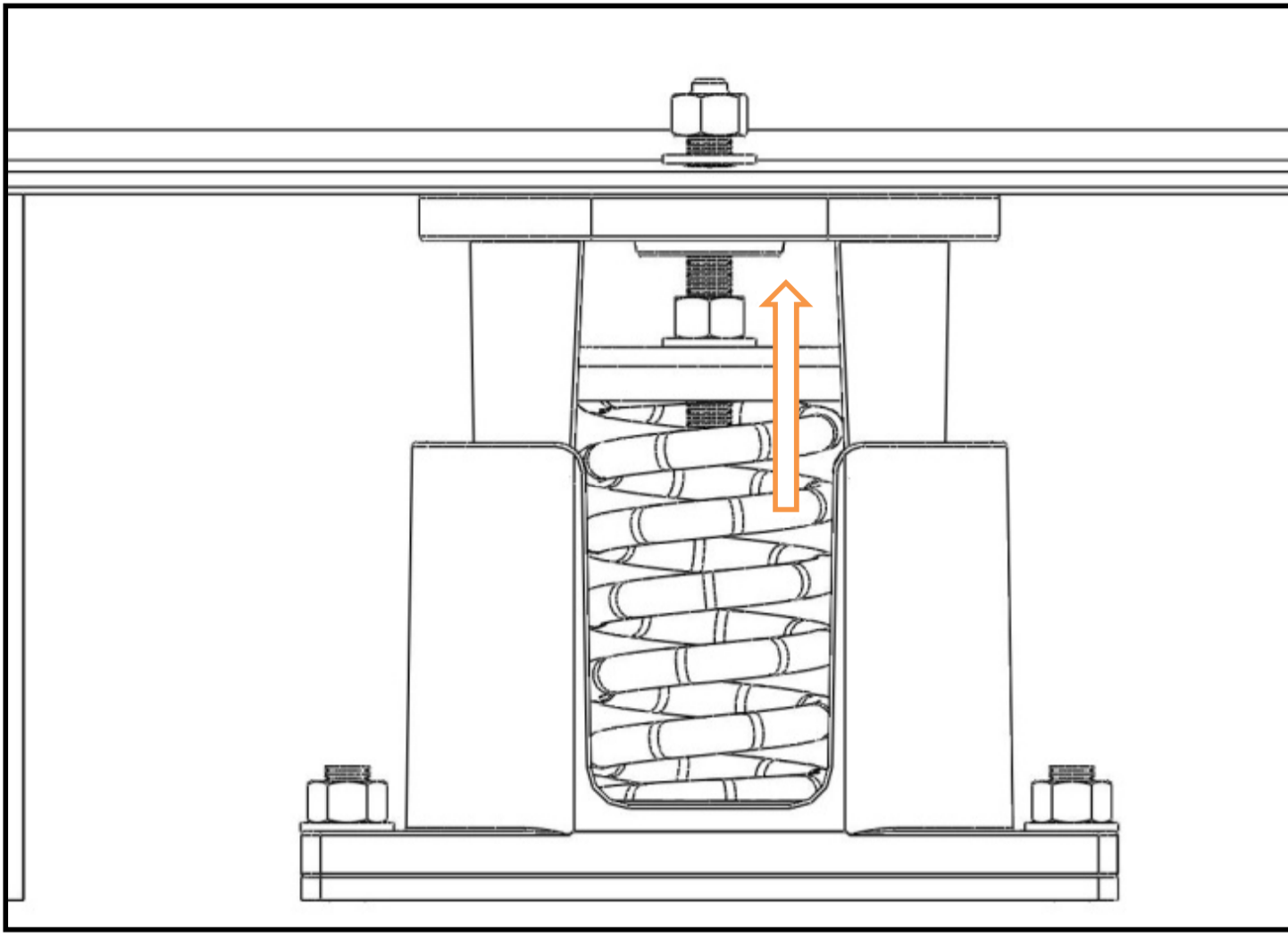
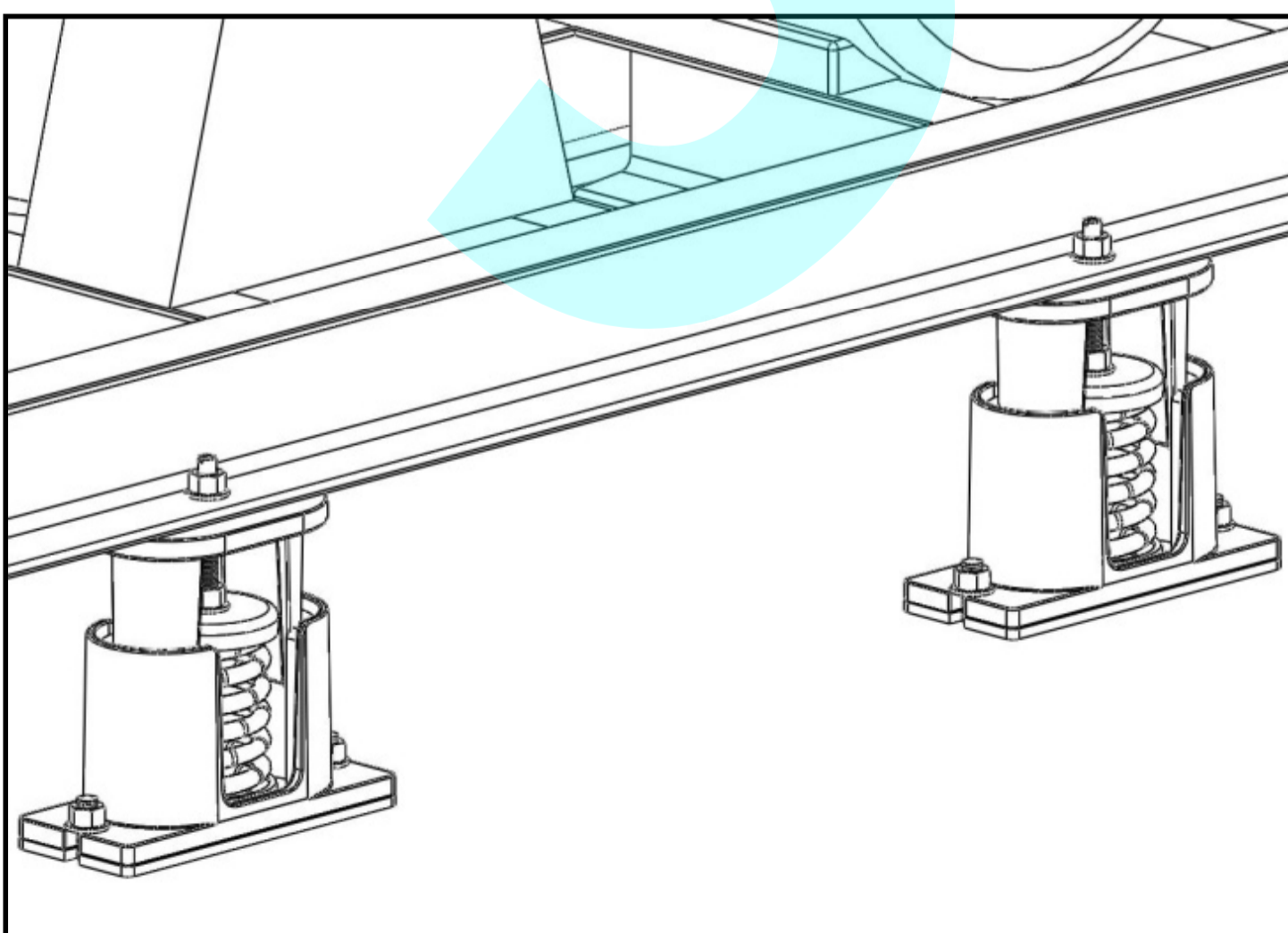
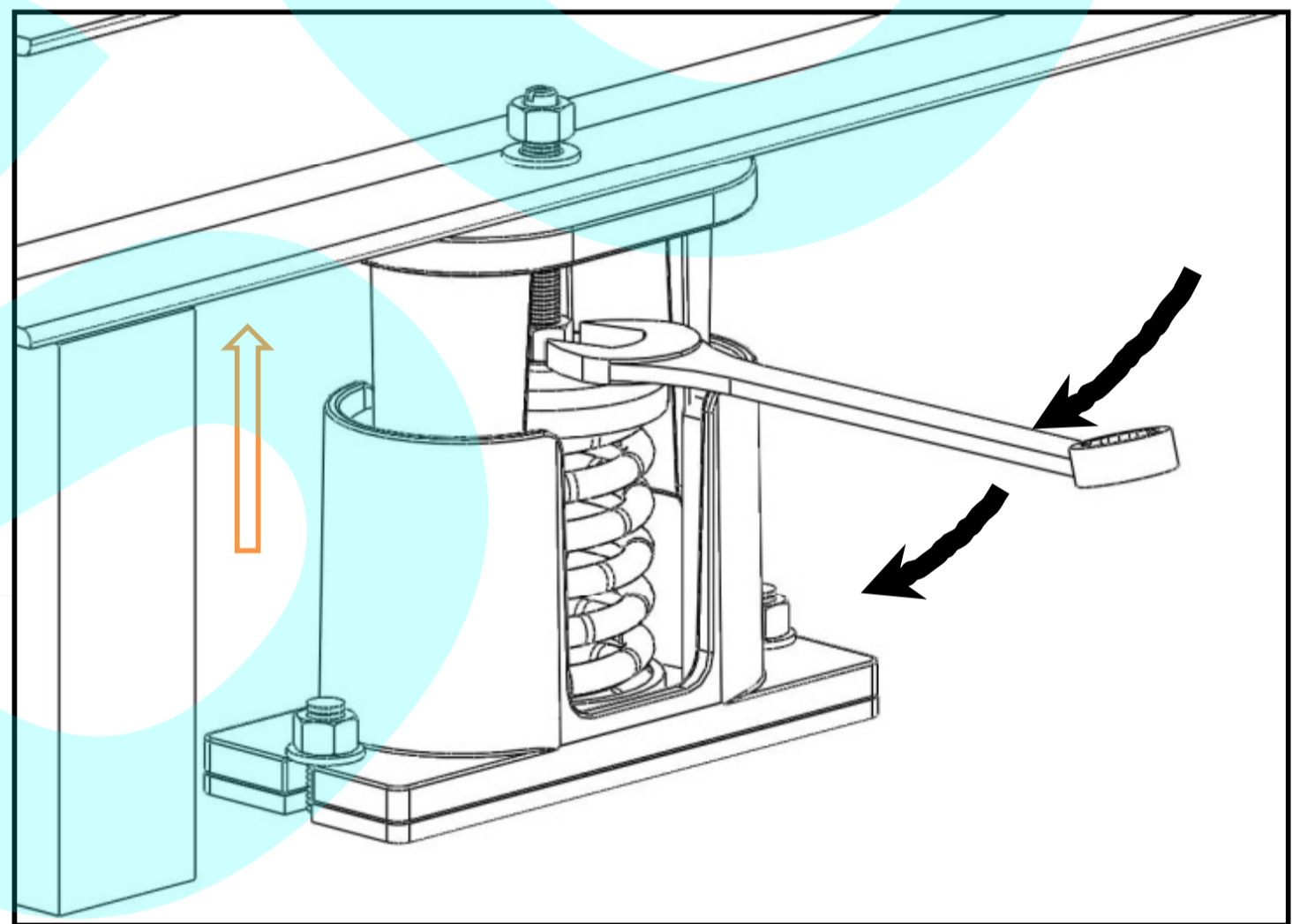

圖6)將固定螺栓與設備完全鎖緊後，即完成避震器安裝調整。

Fig 6) After the adjustment, lock the isolator with fixed bolt.